

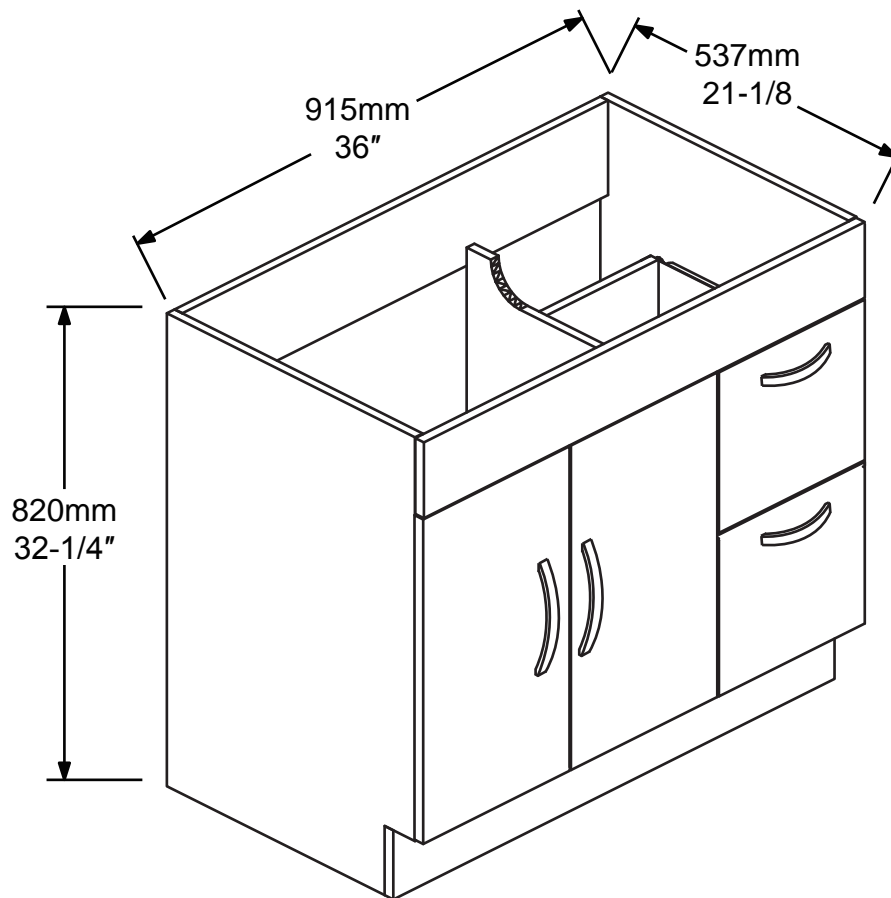

BATHROOM FURNITURES • MOBILIERS DE SALLE DE BAIN

Vanity • Meuble-lavabo

19-VF3621GB



- Melamine board construction
- Flat style 2 doors and 2 drawers
- BN ARC handles
- Doors and drawers with soft close
- Adjustable hinges
- Easy to assembled

- Construction en bois mélamine
- 2 portes de style plat et 2 tiroirs
- Poignées en BN ARC
- Portes et tiroirs avec fermeture lente
- Charnières réglables
- Facile à assembler

Tools You Will Need - Outils Requis



Power drill
Perceuse électrique



Screwdriver
Tournevis



Pencil
Crayon



Glue
Colle

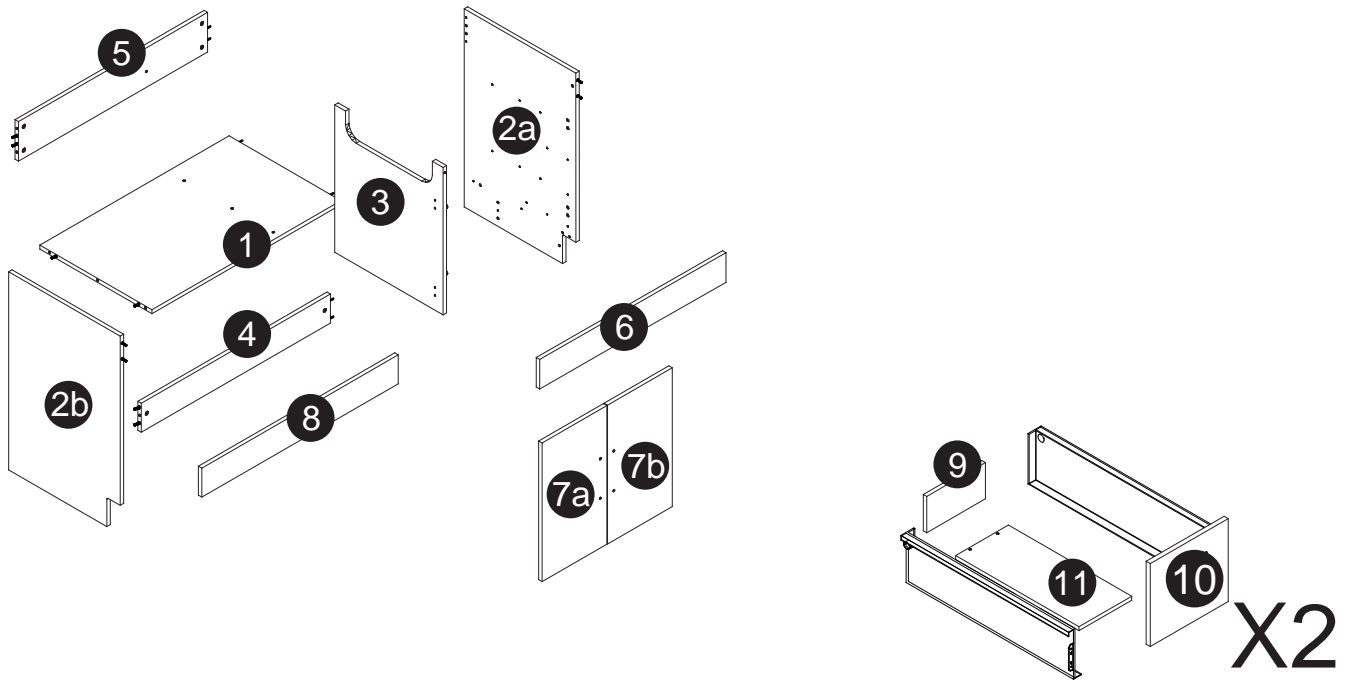

Size / Dimension:

NUM	DIMESION / SIZE: W x T x D (mm)	QTÉ / QTY	NUM	DIMESION / SIZE: W x T x D (mm)	QTÉ / QTY
1	34-3/4" x 5/8" T x 20-1/2"	1	7a	22-7/8" x 5/8" T x 11-7/8"	1
	882 x 16T x 520			580 x 16T x 302	
2a	20-1/2" x 5/8" T x 32-1/4"	1	7b	22-7/8" x 5/8" T x 11-7/8"	1
	520 x 16T x 820			580 x 16T x 302	
2b	20-1/2" x 5/8" T x 32-1/4"	1	8	36" x 5/8" x 4-3/4"	1
	520 x 16T x 820			915 x 16T x 117	
3	19-13/16" x 5/8" x 24-1/4"	1	9	11-7/8" x 5/8" T x 5-1/4"	2
	503 x 16T x 616			246 x 16T x 133	
4	34-3/4" x 5/8" x 4-5/8"	1	10	11-7/8" x 5/8" x 11-3/8"	2
	882 x 16T x 117			302 x 16T x 289	
5	34-3/4" x 5/8" x 6-1/4"	1	11	15-5/8" x 5/8" x 9-5/8"	2
	882 x 16T x 160			397 x 16T x 246	
6	35-7/8" x 5/8" T x 4-3/4"	1			
	912 x 16T x 120				

Part List / Liste de pièces:

Part List / Liste de pièces:			Master Part :
			A. Screw / Vis
55 X A	13 X B	13 X C1	B. Metal cam / Vis pour cam-lock
			C1. Cap for cam-lock / Capuchon pour cam-lock
8 X D	4 X E	2 X F	D. Screw for drawer box board and partition panel / Vis de boîte de tiroir bord et panneau de séparation
			E. Hinge part on side panels / Charnière côté panneau
2 X F1	44 X G	2 X H	F. Hinge part on doors / Charnière côté porte
			F1. Hinge part on doors next to drawers / Charnière partie sur les portes à côté de tiroirs
2 X H1	8 X O	8 X P1	G. Screw for drawer slides, boxes and soft closing / Vis pour glissières de tiroirs, boîte et fermeture en douceur
			H. Handle for doors / Poignée pour portes
2 X P	2 X Q	5 X S	H1. Handle for drawers / Poignée pour tiroirs
			O. Screw for Hinge part on doors / Vis pour Charnière côté porte
2 X SD(L+R)	2 X SB(L+R)	2 X T(L+R)	P1. Screw for handle / Vis pour poignée
			P. Plastic plug / Bouchon en plastique
6 X W	2 X Y(L+R)		Q. Screw for back panel / Vis pour panneau arrière
			S. L-shape metal plate to fix boards together / L-forme plaque de métal à fixer planches ensemble
			T(L+R). Drawer soft closing / Dessinateur fermeture en douceur
			SB(L+R). Metal drawer slides on side panel / Glissières de tiroirs en métal sur le panneau latéral
			SD(L+R). Metal drawer slides on drawer box / Glissières de tiroirs en métal sur la boîte de tiroir
			W. Bumper / Pare-chocs
			Y(L+R). Metal clip parts on SD(L+R) for T(L+R) / Parties de clip en métal sur SD(L+R) pour T(L+R)

Step 1 / Étape 1

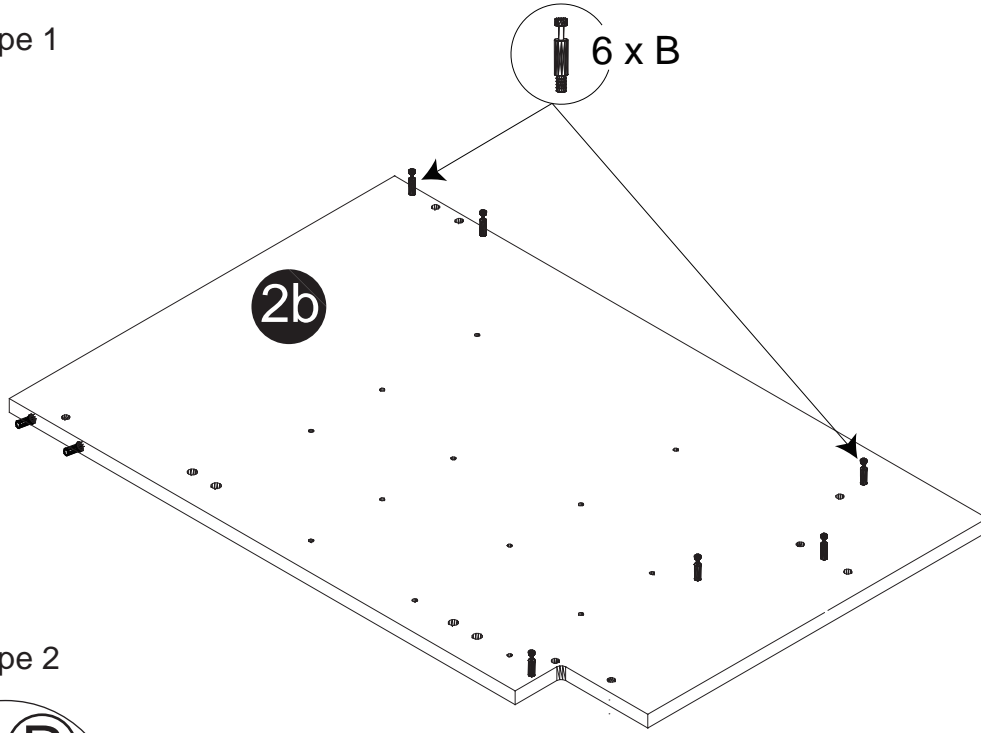

Step 2 / Étape 2

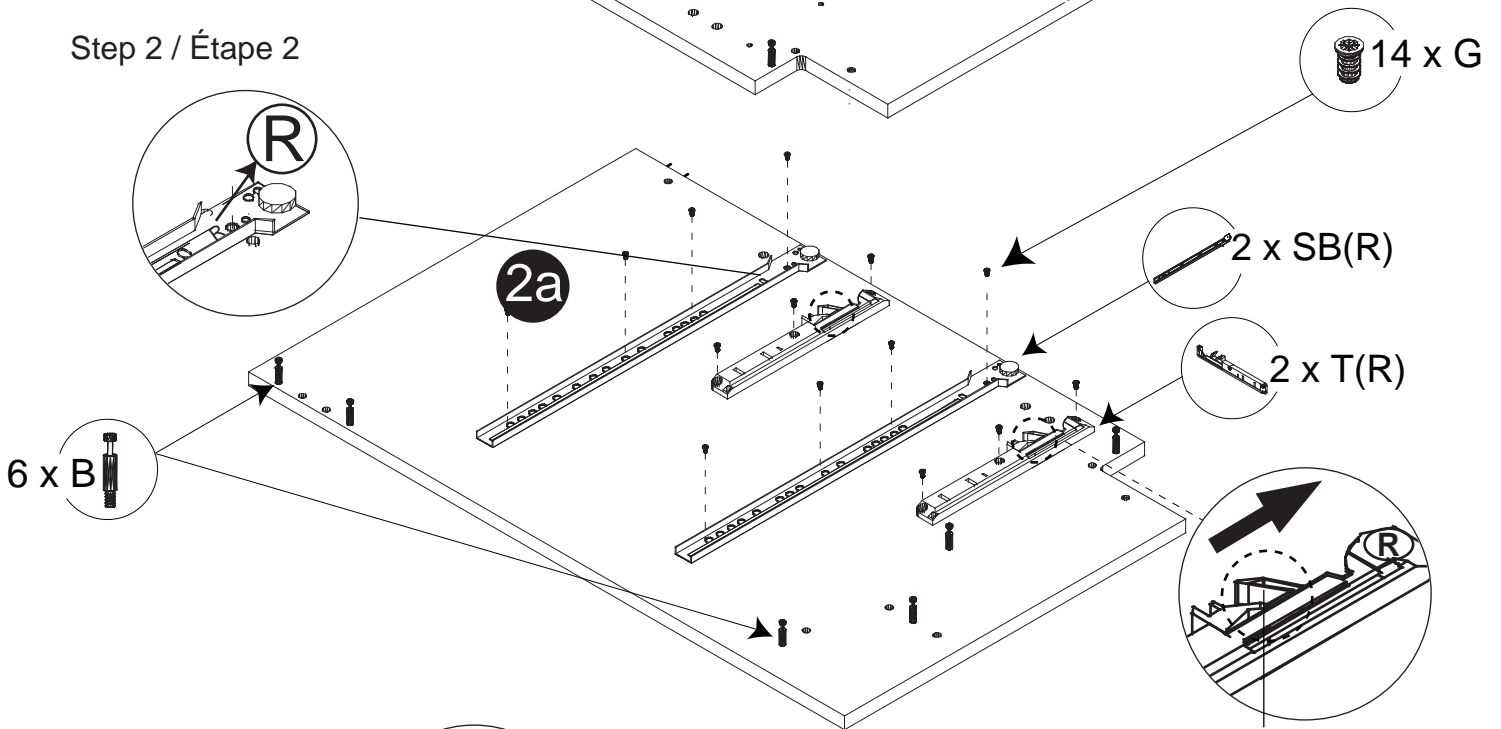

Step 3 / Étape 3

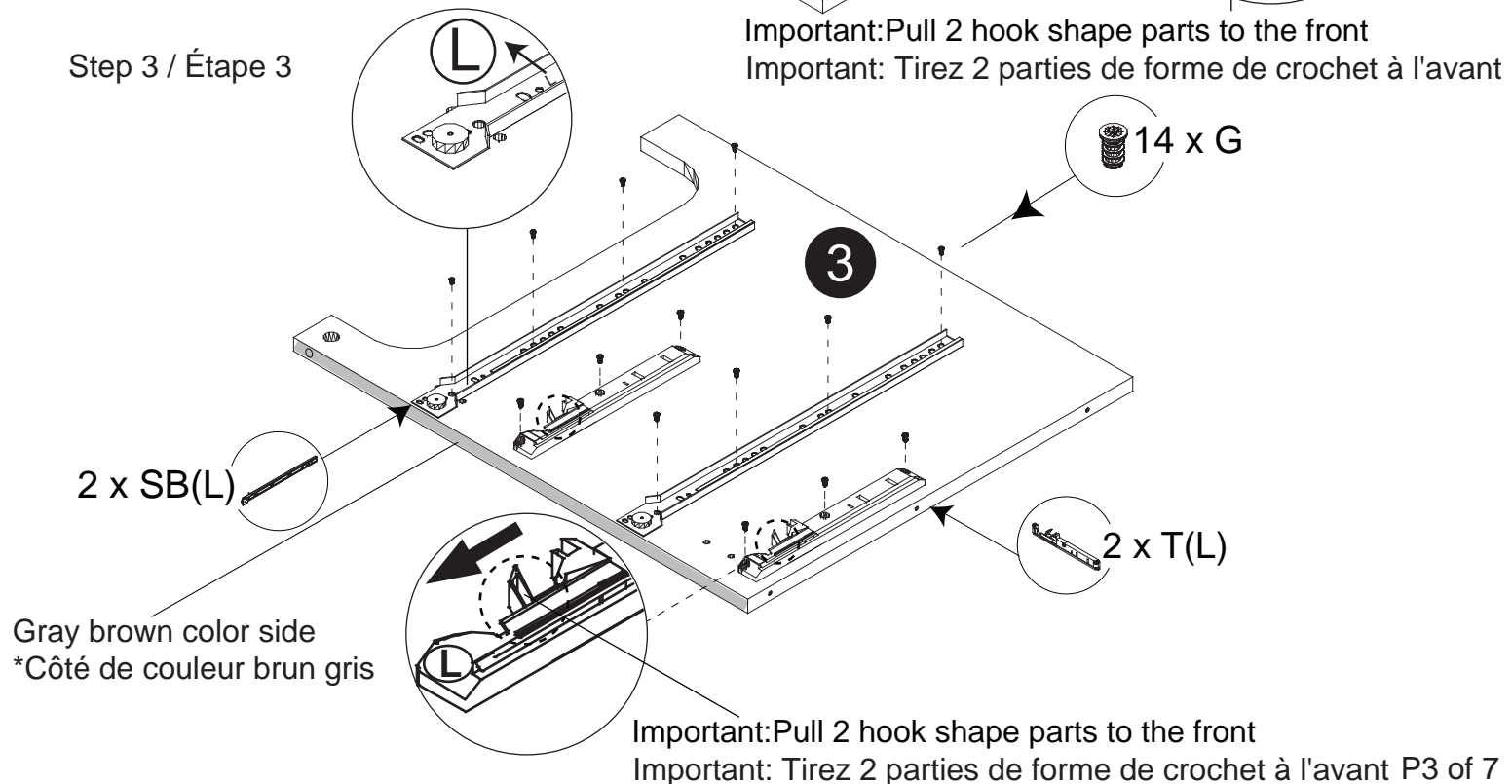

Step 4 / Étape 4

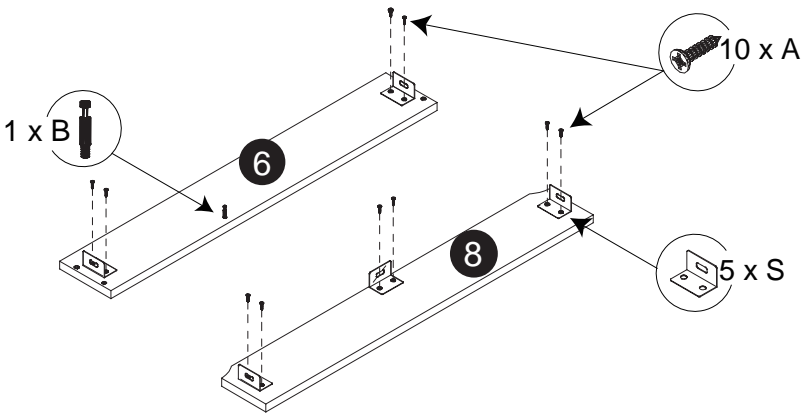

Step 5 / Étape 5

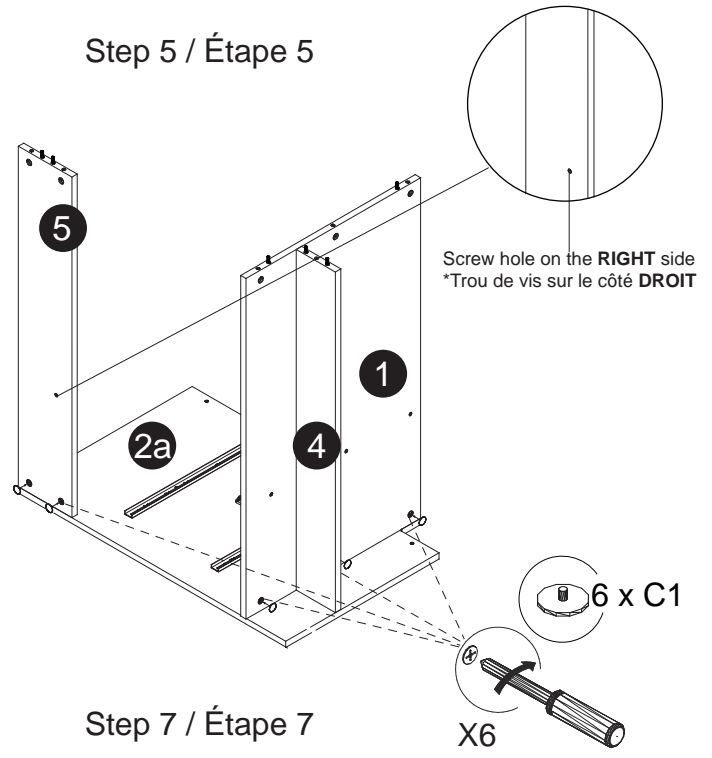

Step 6 / Étape 6

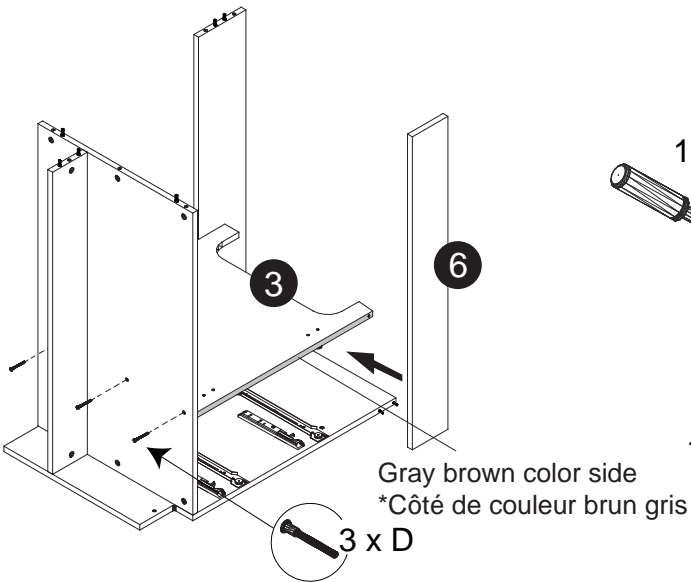

Step 7 / Étape 7

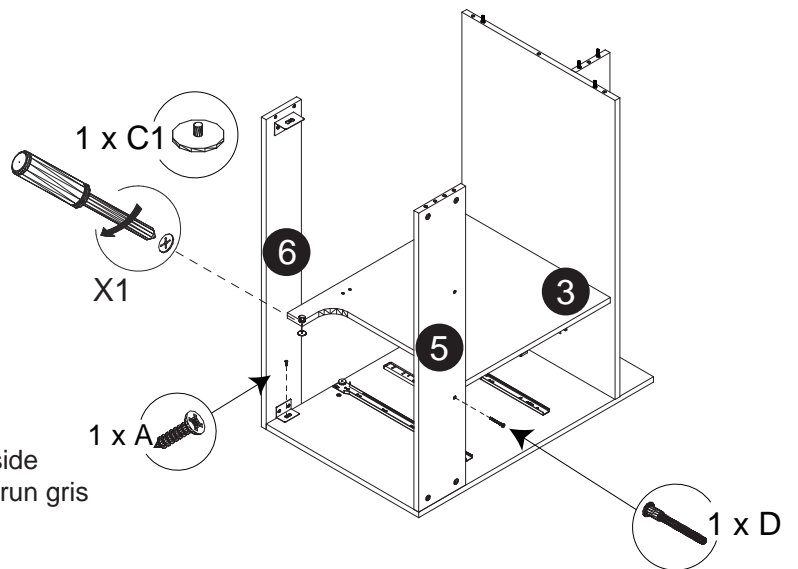

Step 8 / Étape 8

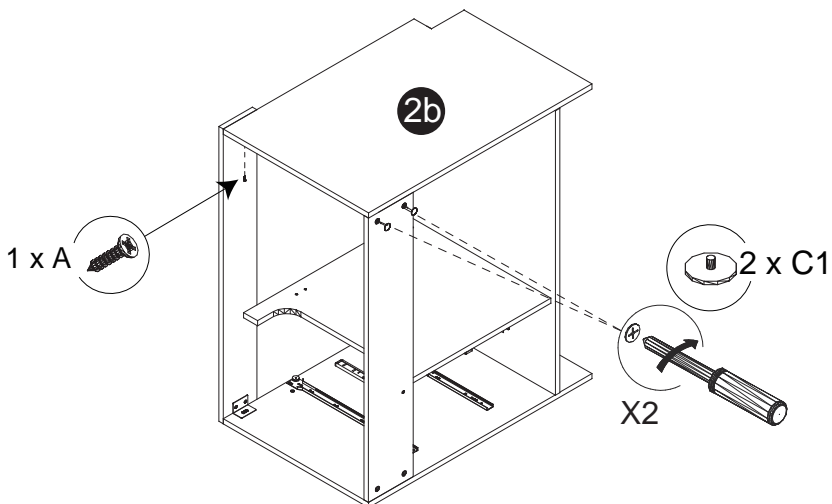

Step 9 / Étape 9

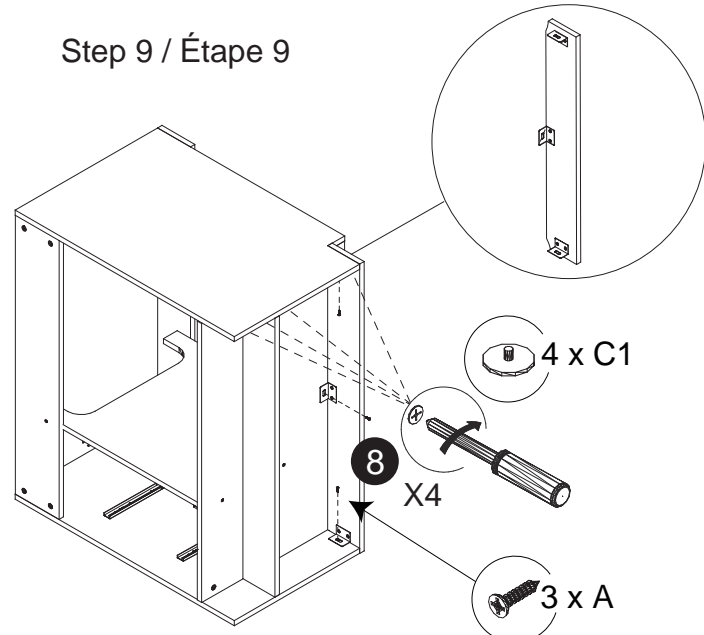

Step 10 / Étape 10

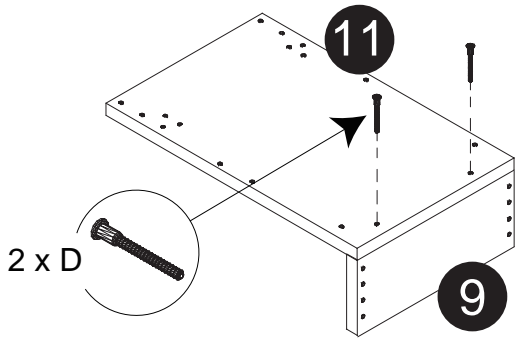

X2

Step 11 / Étape 11

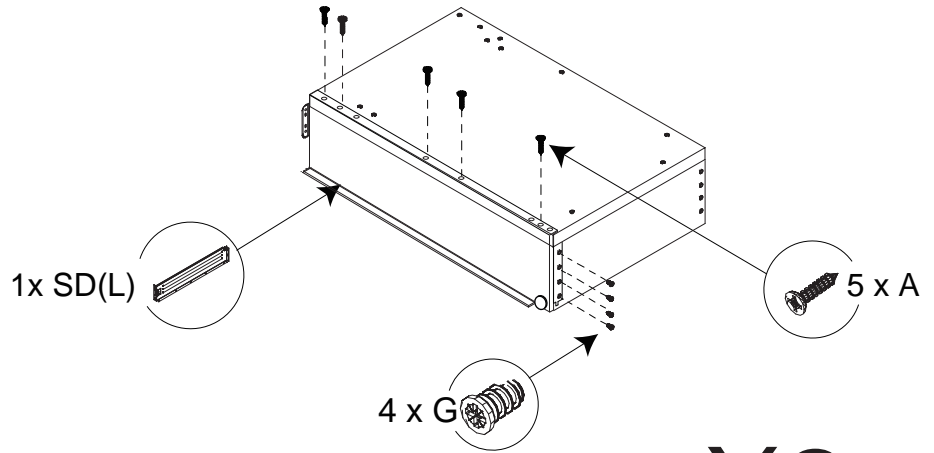

X2

Step 12 / Étape 12

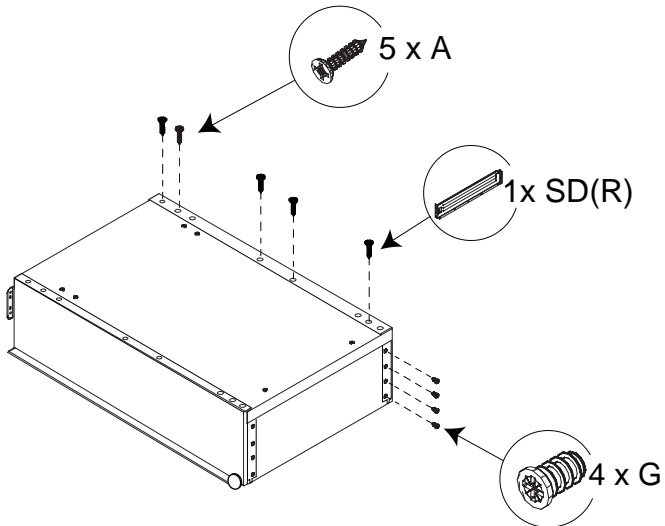

X2

Step 13 / Étape 13

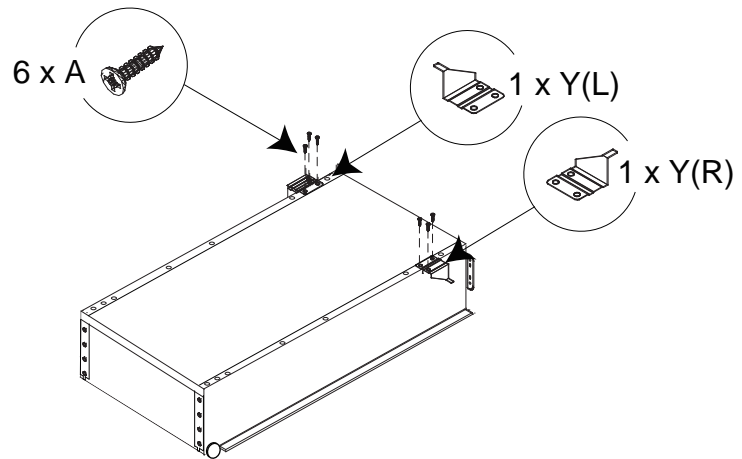

X2

Step 14 / Étape 14

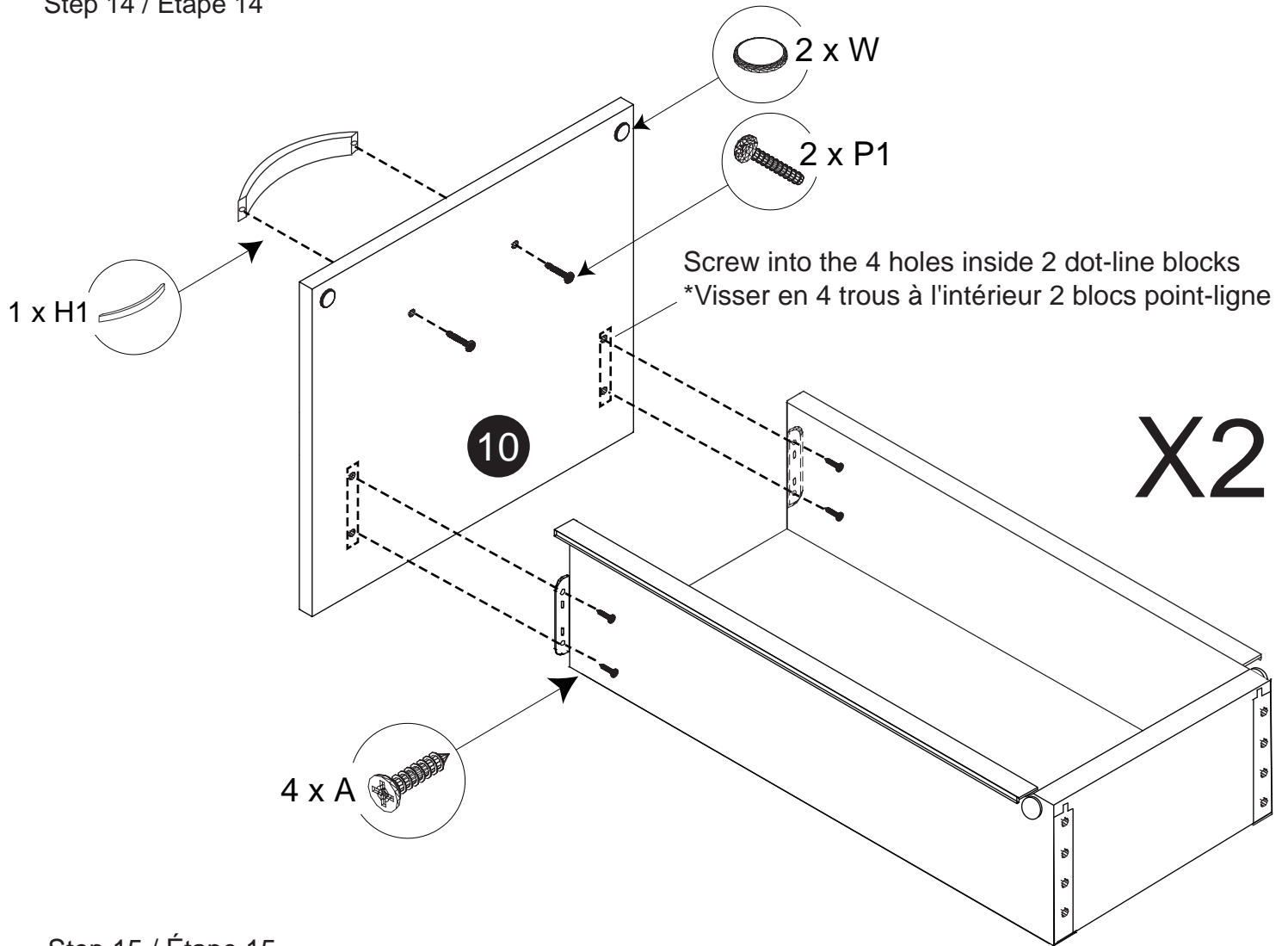

Step 15 / Étape 15

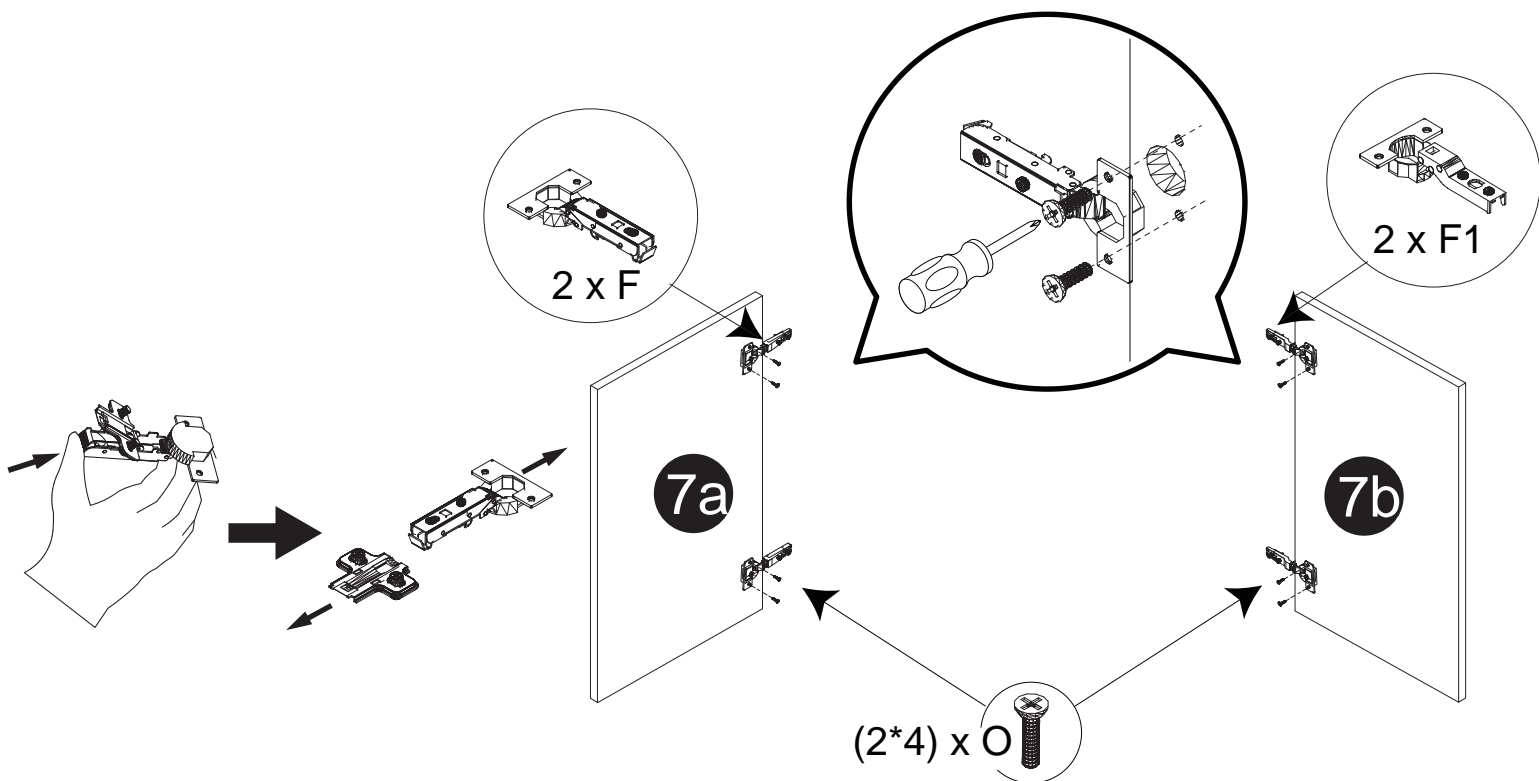

Step 16/ Étape 16

Drawer orientation adjustment
*Réglage d'orientation de tiroir

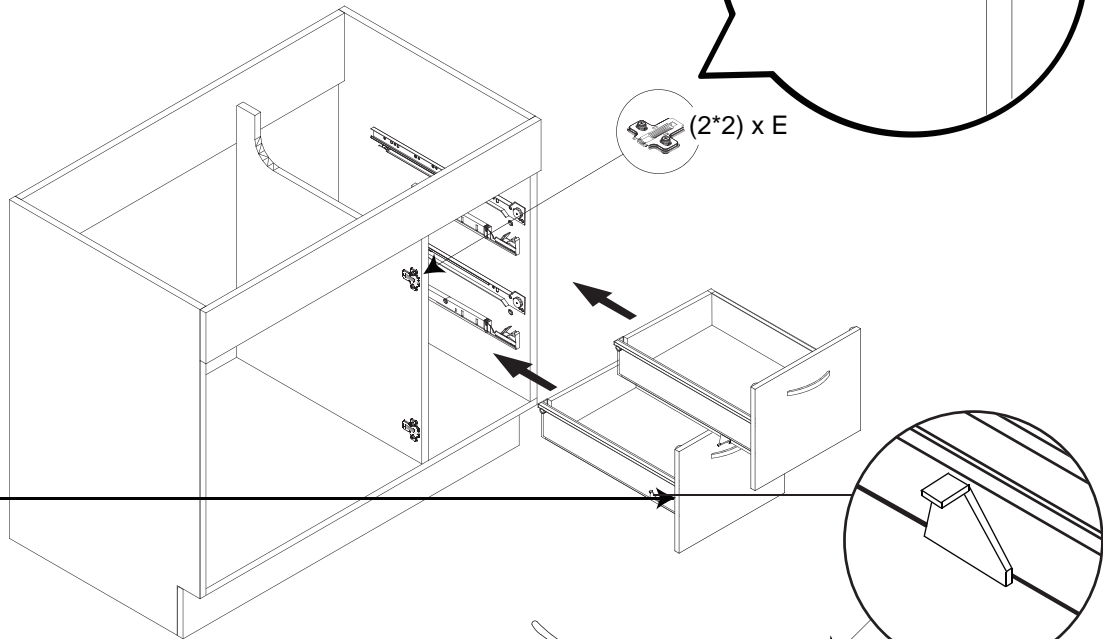
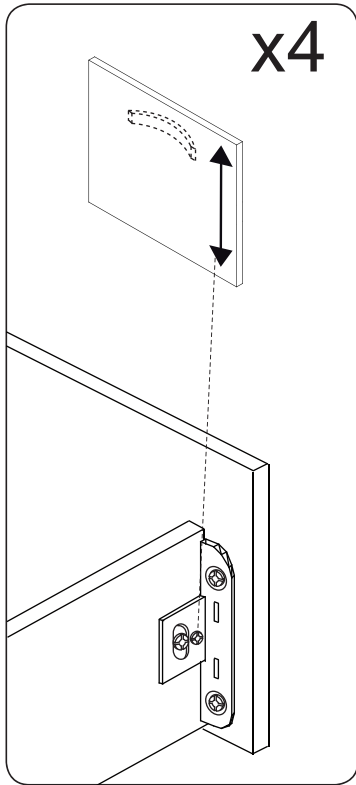

Drawers function check:

①

First please check the step 2 and step 3
ALL 4 hook shape parts have pulled to front.

*Première s'il vous plaît vérifier l'étape 2 et l'étape 3
Toutes les pièces en forme de crochet 4 ont tiré à l'avant

②

keep/press the drawer down
during the drawer opening or closing.

*garder / appuyez sur le tiroir
vers le bas lors de l'ouverture du tiroir
ou la fermeture.

③

If you can not open and close drawer smoothly,
please Use pliers to adjust the extend-pin lower a little bit
as the above drawing shown.

*Si vous ne pouvez pas ouvrir et fermer le tiroir en douceur,
s'il vous plaît Utilisez des pinces pour ajuster l'étendue broches
baisser un peu le schéma ci-dessus indiqué.

Step 17/ Étape 17

Door orientation adjustment
*Réglage d'orientation de porte

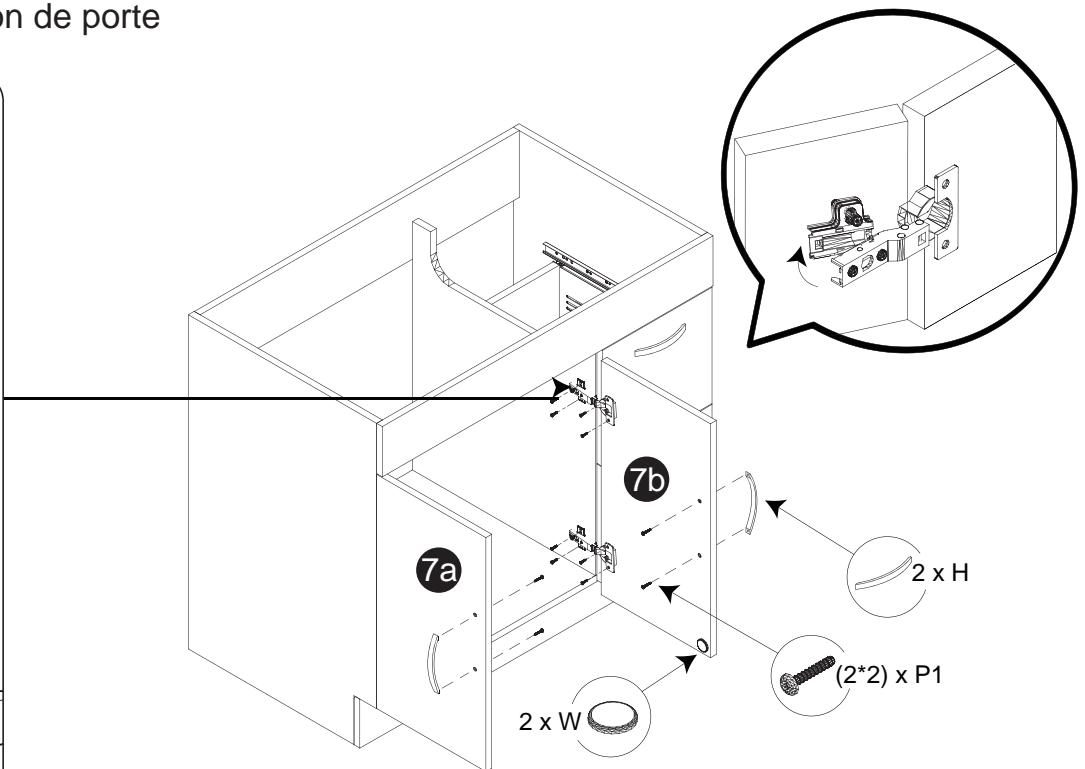
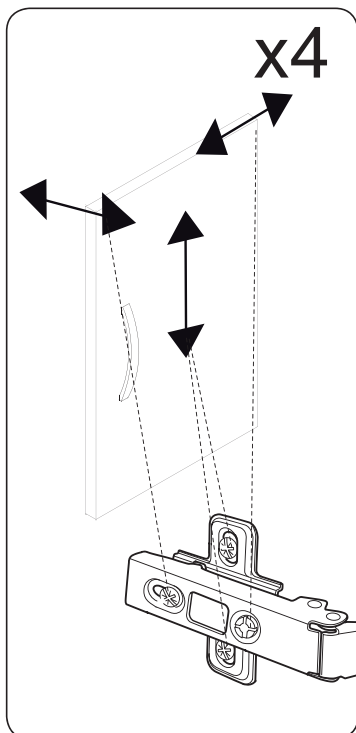

The vanity wall mounting screws need to be fixed onto the studs behind the dry wall board. Locate and mark the stud positions with a stud finder, drill pilot mounting holes at marks onto desire studs. Insert the plastic screw sleeves into drilled mounting holes on wall. Drill the screw holes on vanity back panel to match the mounting holes on wall. Install the mounting screws through the vanity back panel, dry wall board to the studs.

*Les vis de fixation murale vanité doivent être fixés sur les montants derrière le panneau mural sec. Repérez et marquez les positions des goujons avec un détecteur de montants, percer des trous de montage pilotes à des marques sur les goujons de désir. Insérez les douilles à vis en plastique dans les trous de montage percés sur le mur. Percez les trous de vis sur la vanité panneau arrière pour faire correspondre les trous de fixation sur le mur. Installez les vis de montage à travers le panneau arrière de la vanité, panneau de cloison sèche sur les poteaux.

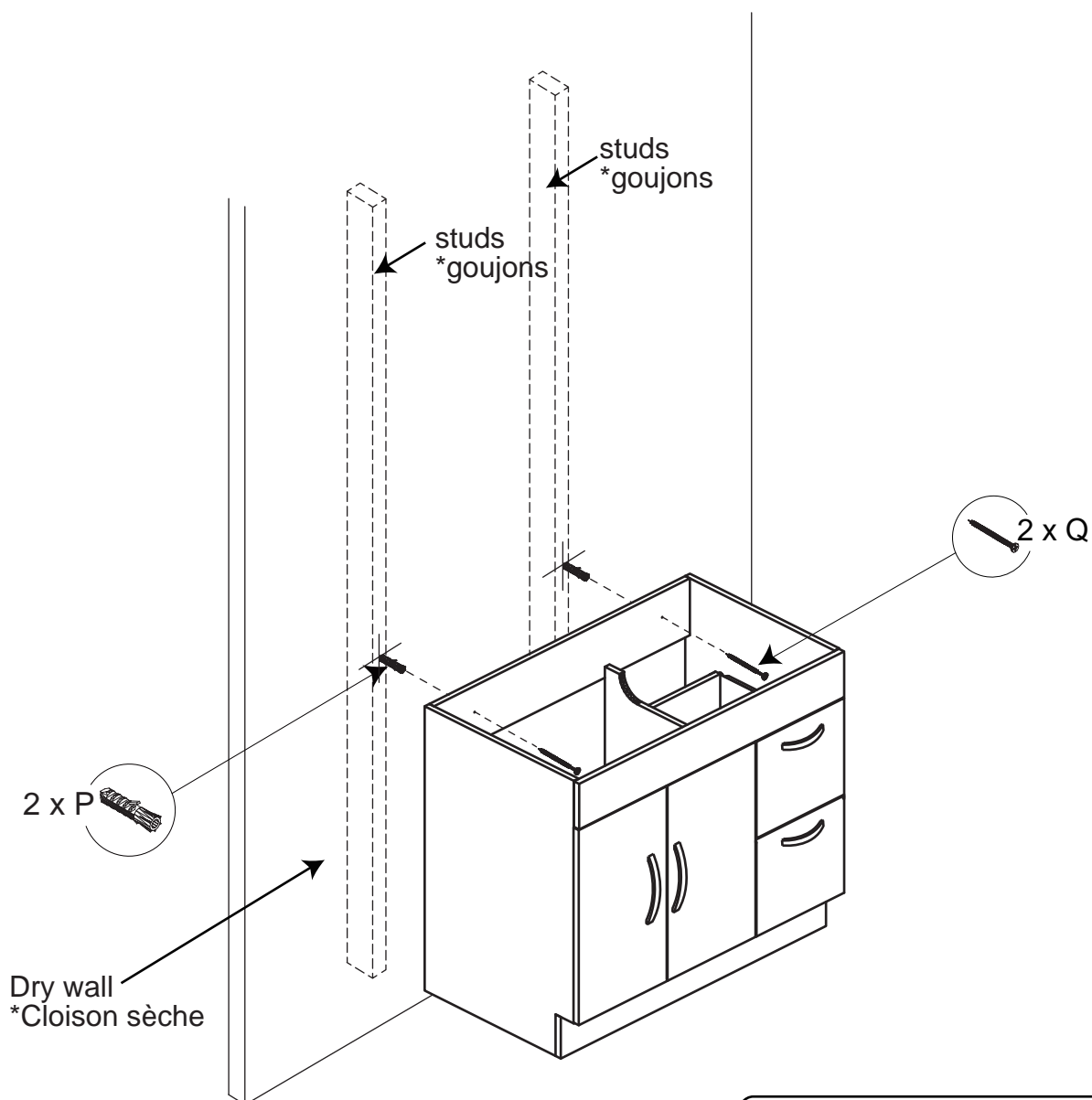

Tools You Will Need - Outils Requis



stud finder
finder stud